

# Micro Ohmmeter RMO400G

- Lightweight - only 9 kg
- Powerful 5 A – 400 A DC
- Measuring range 0 – 999,9 mΩ
- Resolution to 0,1 μΩ
- SINGLE / CONTIN Mode
- True DC current



## High DC current resistance meter

### Description

RMO400G is a Micro Ohmmeter based on a state of the art technology, using the most advanced switch mode technique available today. RMO400G generates a true DC ripple-free current with automatically regulated test ramps. During a test the RMO400G ramps with increasing current before measuring and decreasing current after the measurement. This eliminates magnetic transients. After the test current has been set, the automatic test procedure is started by pressing the Ω-button.

The RMO400G instrument can store internally up to 500 measurements. All measurements are time and date stamped. Using the DV-Win software a test can be performed from a user's PC, and the results can be obtained directly on the PC. Communication between the RMO400G and a PC is through an USB (as standard) or an RS232 cable (as an option). Using the DV-Win the result can be arranged as an Excel spreadsheet which can be later shown as a diagram and printed for a report.

The set is equipped with a thermal and an overcurrent protection. The RMO400G has a very high ability to cancel electrostatic and electromagnetic interference in HV electric fields. It is achieved by very efficient filtration. The filtration is made utilizing a proprietary hardware and software.

### Output Ratings

The full output is available from the RMO400G at 230 V Mains Supply. A reduced output is available from lower supply voltages.

Supply Voltage	Output Current	Full Load Voltage
230 V AC	400 A DC smoothed	6,70 V DC
	200 A DC smoothed	7,30 V DC
115 V AC	400 A DC smoothed	3,40 V DC
	200 A DC smoothed	6,30 V DC

Output current is filtered and has a ripple of less than 1 %. The RMO400G current output is rated at 300 A for 60 seconds, at 200 A for 150 seconds and 100 A for 5 minutes at 25°C ambient temperature.

## CONTIN Mode

RMO400G can generate a DC current continuously using the CONTIN menu. In this menu the current can be chosen the same way as in the SINGLE menu, but the duration of the test can be preset. The test is started pressing the  $\Omega$ -button. During the test, a new result is shown on the display and stored into the PC (DV-Win) each second. Using DV-Win the result can be arranged as an Excel spreadsheet which can be later shown as a diagram and printed for a report.

## Application

Typical application is measuring resistance of:

- High, middle and low voltage circuit breakers
- High, middle and low voltage disconnecting switches
- High-current bus bar joints
- Cable splices
- Welding joints

## Accessories

### Included

- DV-Win PC software
- Ground cable
- USB cable

### Recommended

- Current cables 2 x 5 m 35 mm<sup>2</sup> with battery clips
- Sense cables 2 x 5 m with alligator clips
- Cable bag

### Optional

- Built-in thermal printer
- Thermal paper roll
- Both Sides Grounded Unit
- Test shunt 600 A / 60 mV
- Current cables 2 x 10 m 35 mm<sup>2</sup>
- Current cables 2 x 15 m 50 mm<sup>2</sup>
- Extension cable 2 x 10 m 50 mm<sup>2</sup>
- Sense cables 2 x 10 m with alligator clips
- Sense cables 2 x 15 m with alligator clips
- Cable plastic case



Voltage sense cables



Current cables



Extension cable



Test shunt



Cable bag



Current clamp 30/300A + cable set 5 m

### Connecting a Test Object to RMO400G

With RMO400G turned off, connect RMO400G to the test object ( $R_x$ ) in such a way that the measuring cables from the "Voltage Sense" sockets are attached as close as possible to  $R_x$ , and in between the current feeding cables. That way, a resistance of both cables and clamps is almost completely excluded from the resistance measurement.

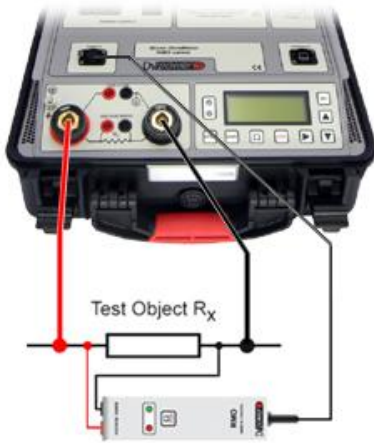
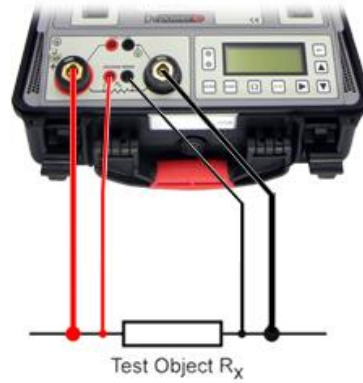

### Remote Control Unit

The RMO Remote Control Unit is an optional control unit that is used to start and stop the tests from a remote location, away from the actual RMO.

Provided that, for a series of tests, the same test current is fed through the test object, multiple measurements can be carried out

### Both Sides Grounded Unit

Using RMO400G with both sides grounded option it is possible to make safer measurement of breakers with both terminals of the breaker grounded. Measuring the current through the ground connection and reducing this value from the total current is an additional safety feature.

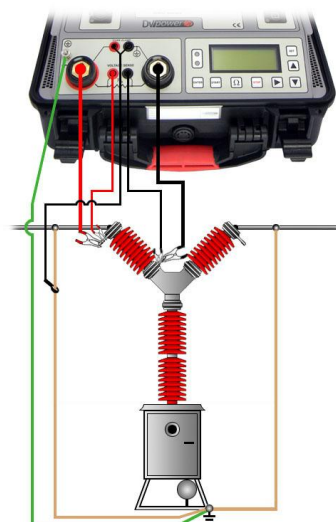

## Technical Data

### 1 - Mains Power Supply

- Connection	according to IEC/EN60320-1; C320
- Voltage	90 V – 264 V AC, 50 / 60 Hz, single-phase
- Power consumption	3250 VA (230 V AC); 2300 VA (110 V AC)
- Fuse	15 A / 230 V, type F

### 2 - Output data

- Test current	5 A – 400 A DC
- Measuring range / Resolution	
0,1 $\mu\Omega$ - 999,9 $\mu\Omega$	0,1 $\mu\Omega$
1000 $\mu\Omega$ - 9999 $\mu\Omega$	1 $\mu\Omega$
10,00 m $\Omega$ - 99,99 m $\Omega$	10 $\mu\Omega$
100,0 m $\Omega$ - 999,9 m $\Omega$	0,1 m $\Omega$
- Typical accuracy	$\pm$ (0,1 % rdg + 0,1 % FS)

### 3 - Environment conditions

- Altitude below 2000 m
- Temperature -10 °C - +55 °C / 14 °F - +131 °F
- Maximum relative humidity 95 % for temperatures up to 31 °C, decreasing linearly to 40 % relative humidity at 55 °C
- Mains supply voltage fluctuations up to  $\pm$ 10 % of the nominal voltage
- Installation/overvoltage category II
- Pollution degree 2

### 4 - Dimensions and Weight

- Dimensions	405 mm x 170 mm x 335 mm 16 in x 6,7 in x 13,2 in (W x H x D) without handle
- Weight	9 kg / 20 lb

### 5 - Warranty

three years

### 6 - Safety Standards

- European standards	EN 61010-1 LVD 2006/95/EC
- International standards	IEC 61010-1 UL 61010-1 CAN/CSA-C22.2 No. 61010-1, 2 <sup>nd</sup> edition, including Amendment 1

### 7 - Electromagnetic Compatibility (EMC)

- CE conformity	EMC standard 89/336/EEC EMC directive 2004/108/EC
- Emission	EN 61326-1
- Interference Immunity	EN 61326-1

*All specifications herein are valid at ambient temperature of + 25 °C and recommended accessories. Specifications are subject to change without notice.*