

Sensors & Accessories

for Partial Discharge (PD) Monitoring Systems

Product Catalogue

Coupling
Capacitors

RTD Based
PD Detection

Ground Path
Current Sensors

Radio Frequency
Current Transformers

Bushing Insulation
& PD Sensors

Rogowski Coils

Features & Benefits

- Superior Designs
- Ease of Installation
- Built-in Protection Features
- Detection of Fault Inception Points
- Facilitates Data Correlation & Advanced Filtering



Table of Contents

Overview 2-3

Coupling Capacitors 4-5

RTD-PD Sensor Modules for RTDs 6-7

Ground Path Current Sensors 8-9

Radio Frequency Current Transformers 10-11

Bushing Sensors 12-13

Rogowski Coil Sensors 14-15

Ambient Temperature & Humidity Sensors 16

Top Oil Temperature Sensors 17

Load Current Sensors 18

Notes 19

Overview

Partial Discharge (PD) sensors are used to detect problems in numerous types of electrical apparatus including:

- **Generators**
- **Power Transformers**
- **Switchgear**
- **Motors**
- **Iso-Phase Bus**
- **Cables**



Dynamic Ratings (DR) provides a variety of sensors used to detect (PD) occurring in the insulation of electrical apparatus.

These sensors couple the high frequency partial discharge pulses into measuring instruments to process the data into meaningful outputs. DR provides permanent on-line partial discharge monitors or portable monitors.

DR sensors are designed to be highly sensitive and accurate to the property of interest. Where industry could not provide sensors with the quality, accuracy and performance required in our customer's harsh and demanding applications, DR has developed and patented its own sensors to exceed industry standards for quality and performance coupled with ease of installation.



Multiple Sensor Types

Dynamic Ratings provides a wide variety of PD sensors for various electrical equipment applications, these sensors include:

- **Coupling Capacitors:** are typically applied to motors, generators, switch gear and bus duct.
- **RTD Modules:** utilise existing RTDs embedded within the windings of rotating equipment to provide additional winding coverage.
- **Ground Path Current Sensors:** are typically applied to iso-phase bus duct and ungrounded HV cable shields. This sensor, when used with other sensor types can assist in determining the direction of PD activity.
- **Radio Frequency Current Transformers:** are typically applied to grounded cable shields and the neutral connection on large power transformers.
- **Bushing Sensors:** are typically applied to bushings on power transformers and high voltage current transformers. The sensors provide both high frequency signal detection for partial discharge detection and low frequency detection for bushing monitoring.
- **Rogowski Coils:** complement the bushing sensors to provide a directionally sensitive indication of PD activity, allowing the monitoring equipment to recognise the difference between internal PD sources and externally generated signals.

Comprehensive System Monitoring

PD monitoring systems that utilise a variety of complementary sensors installed at different points have several advantages:

- **Improved Detection:** Using complementary sensor types at various sensing points provides added sensitivity, and improves monitoring system coverage.
- **Avoids False Alarms:** The use of directionally sensitive sensors enables monitoring equipment to utilise more advanced filtering methods. These improved filtering methods enable the monitoring equipment to identify and filter out externally generated signals.
- **Faster Fault Location:** With added sensing points, the monitoring instrumentation can utilise directional signals, time of arrival, signal patterns and other diagnostic approaches to identify the source of the problem.
- **Direct Measurement:** The direct measurement of electrical PD signals provides higher sensitivity compared to secondary sensing approaches such as acoustic, TEV, ozone detection, etc.

Complementary Sensors

- **Ambient Temperature & Humidity, Top Oil and Load Current Sensors:** PD systems that monitor environmental and equipment operating conditions provide additional benefit. The ability to correlate changes in PD activity based on changes in load, temperature or humidity can enable a Subject Matter Expert to...

Example 1... on rotating equipment, by comparing PD activity with winding temperature, to determine if the root cause is silicon carbide coating at the slot exit points or if the coils are loose in the slot.

Example 2... compare PD activity to a dissolved gas analysis (DGA) diagnostic. A DGA can identify fault gas generation indicating partial discharge problems and the partial discharge system can complement this with added identification, specifically adding the winding and phase generating the fault gasses.

Applications

- Generators
- Switchgear
- Motors
- Iso-Phase Bus
- Power Transformers



The Coupling Capacitor is a versatile partial discharge sensor commonly used to detect PD in many applications including generators, switchgear, motors, isolated phase bus (IPB) and power transformers.

Multiple Voltage Class Designs

DR offers a full complement of Epoxy Mica coupling capacitors. Typically coupling capacitors (CC) are connected to equipment at the line terminal. Three voltage levels are available: 8, 16 and 28 kV.

The epoxy resin used in the capacitors is specifically designed for high voltage insulator applications. This material provides: excellent insulation properties, mechanical strength and superior resistance to chemicals including concentrated acids. It has superior arc resistance as compared to standard electrical grade epoxy materials and meets UL 94/V-0 requirements.

Installation Recommendations

Capacitors are to be located as close to the winding as physically possible to reduce the attenuation effect. For more information request our Application Guide “Importance of Bandwidth and Signal Attenuation.”

On Hydro Generators, additional capacitors are installed on the ring bus at the location of each phase group.

Safety Advantages

There are several design factors that differentiate the Dynamic Ratings CC's, resulting in a more reliable product and provide an added margin of safety.

- **Protection is located at the sensor and each sensor is grounded at the point of installation** (shown).



This design approach reduces the exposure of testing personnel to a high voltage electrical shock if the protection within the termination box fails. Our design allows for ease of installation and reduces the risk of higher than planned signal attenuation due to improper installation.

- **Our natural glazed surface prevents absorption of moisture and other contaminants** and thus maintains the dielectric property of the sensor. The molded surface guards against surface tracking. Our superior design eliminates any machining which damages the glazed coating which creates rough, porous surfaces which are susceptible to causing problems or even failure.

- **Uniformity in the capacitive layers and improved dielectric strength** is achieved through the use of capacitive layers produced exclusively from a virgin mica splitting.

- **Improved reliability** is achieved by using a high number of mica sections in the assembly. The increased number of capacitive layers reduces the electrical stress across each layer.



SPECIFICATIONS

Capacitance:	80pF ± 3pF
Temperature Range:	-50°C to 150°C / -59°F to 302°F
Sensitivity:	1pC
Frequency Range:	0.5 MHz to 500 MHz
Dielectric Strength:	775 V/mil

TESTING STANDARDS

Electrical Tracking Resistance	Meets ANSI/IEEE C37.20.2
Voltage Endurance	Withstand 30kV for 1500 Hrs (IEEE 1043)

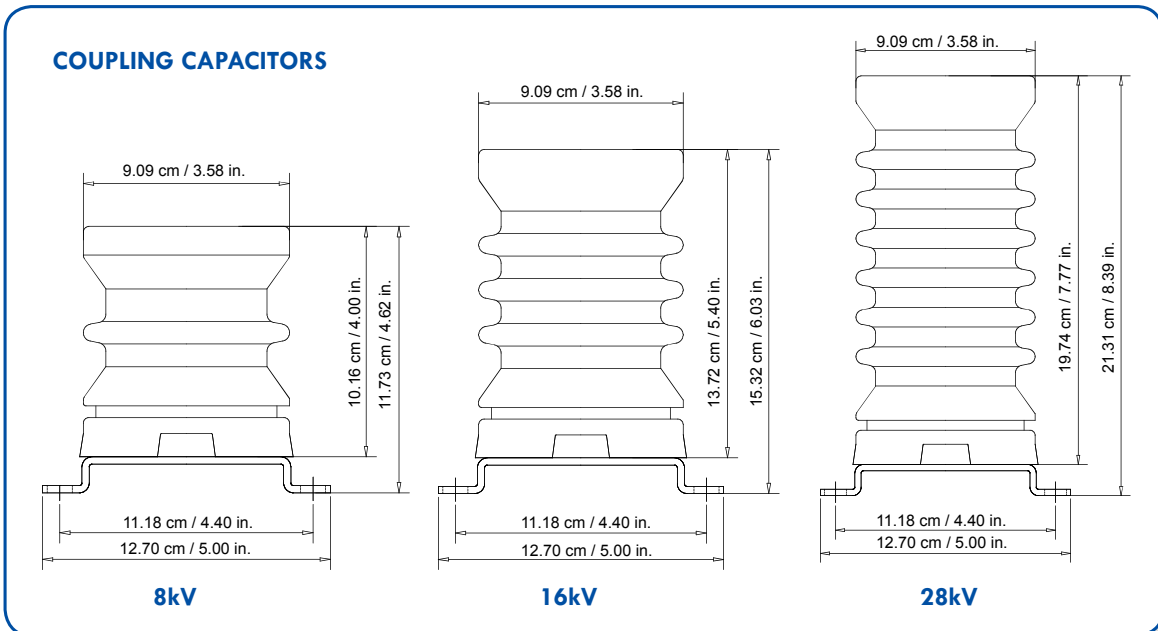

INDIVIDUAL COUPLING CAPACITORS WITH MOUNTING KIT & ACCESSORIES

Part #	Voltage Class	BIL (kV)	Factory Hipot Test (kV)	Description
CC-08-K	8 kV	75 kV	20 kV	One Coupling Capacitor (at specified voltage) including: (1) Mounting bracket (1) Protective boot (1) HV flexible silicone cable (1 m / 3 ft.) with lugs. (1) Mounting hardware kit (1) Open Circuit Protection PCB
CC-16-K	16 kV	100 kV	40 kV	
CC-28-K	28 kV	175 kV	65 kV	
COAX-500	Coax cable, type RG 58A/U, (152 m / 500 ft.) in length			
COAX-1000	Coax cable, type RG 58A/U, (305 m / 1000 ft.) in length			

Coupling Capacitors for new installations are typically ordered (1) kit, per phase. Customers typically order (3) kits. Coaxial Cable is not included. Order desired length of coaxial cable separately.



Applications

- Generators
- Motors

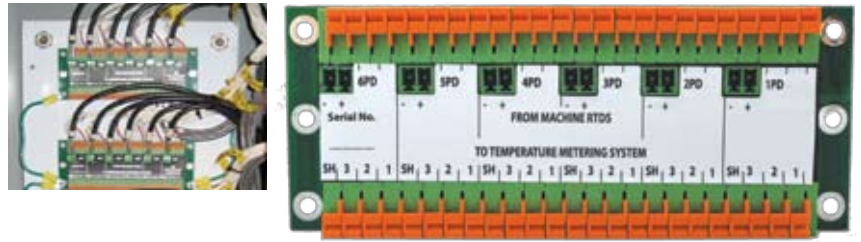

The RTD-PD sensor module provides for the detection of PD activity which may be occurring deep within the windings of a motor or generator. This sensor complements the detection capabilities of coupling capacitors which detect the PD occurring in the stator winding near the equipment terminations.

Operation and Installation

The RTD-PD sensor module allows the use of RTDs to provide a similar sensing capability as a stator slot coupler (SSC). The RTD-PD module (shown above) replaces the terminal strip in the machine junction box.

The RTD-PD is a passive device installed in series with existing RTD wiring. Use of the RTD-PD does not prevent the user from using these RTDs for monitoring winding temperatures.

Use of an RTD-PD expands the “Zone of Coverage” by providing additional detection points throughout a winding. (Refer to the blue circles in figure 3.)

Expanding the Zone of Coverage

Capacitors installed at the line terminals of a machine have a limited “Zone of Coverage” of the machine windings. Typically 10–15% of the winding can be “seen” using coupling capacitors. On a large turbine generator, operators may only see the first bar. Dynamic Ratings has addressed this industry issue.

Customer Benefits

Dynamic Ratings recommends using coupling capacitors and RTDs. The DR complementary sensing strategy of “Coupling Capacitors + RTD’s” increases the Zone of Coverage by 4 to 6 times.

Example... A typical motor or generator with coupling capacitors provides 10–15% coverage. Adding 6 to 12 RTDs (typical) or for a large turbine generator 50 to 60 RTDs increases the Zone of Coverage to 60 – 70% of the winding utilising the RTDs in conjunction with the traditional coupling capacitors.

CASE STUDY

RTD-PD Sensor Module and Coupling Capacitors are Complementary

There are many cases where the PD levels are found to be higher at the RTDs than the coupling capacitors and many cases where the coupling capacitors show higher levels of PD than the RTDs. This is why it is recommended to use both types of sensors simultaneously. The following figures provide examples of each situation.

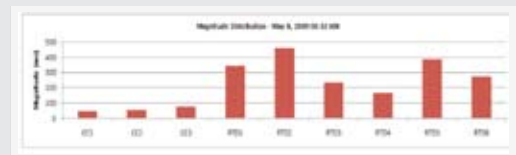

Figure 1
Low PD levels at Capacitors. High PD levels at RTD’s.



Figure 2
High PD levels at Capacitors. Low PD levels at RTD’s.

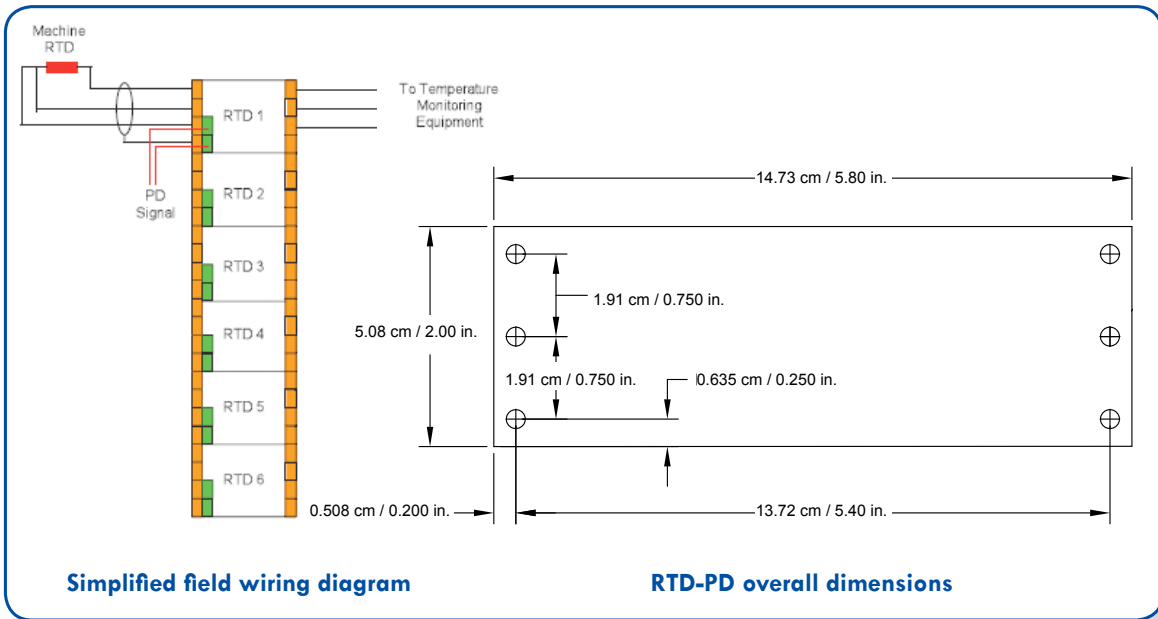

Figure 3
Recommended sensor coverage topology.

Millions of data records exist proving this technology and supporting numerous technical papers both written and presented at major technical conferences detailing the benefits of this complementary PD sensing zone of coverage topology. This topology is currently being used in applications worldwide with great success.

SPECIFICATIONS

Power Requirement:	None (This is a passive device)
Temperature Range:	-40°C to 85°C / -40°F to 185°F
Frequency Range:	500kHz to 75MHz



Sensor Termination Box

A NEMA 4 sensor termination box (BNC-15) is available for use in installations that utilise portable/periodic monitoring equipment such as the DRPD-15. The termination box provides connection for up to 15 PD sensors. BNC connections provide a fast and convenient connection to the monitoring instrument.

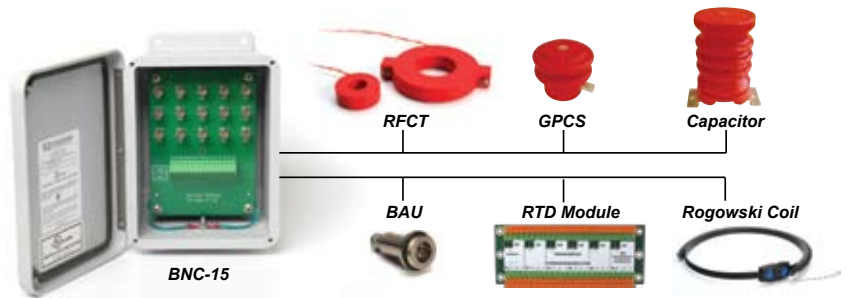

RTD-PD SENSOR MODULE & ACCESSORIES — ORDERING INFORMATION

Part #	Description
RTD-PD	RTD-PD Sensor Module with 6 RTD sensing inputs, 6 RTD signal outputs and 6 PD signal outputs.
BNC-15	A NEMA 4 enclosure to accommodate up to (15) PD sensors using BNC Connectors
COAX-500	Coax cable, type RG 58A/U, (152 m / 500 ft.) in length
COAX-1000	Coax cable, type RG 58A/U, (305 m / 1000 ft.) in length

Coaxial Cable is not included. Order desired length of coaxial cable separately.

Applications

- Iso-Phase Bus
- Switchgear
- Power Transformers



The Ground Path Current Sensor (GPCS) provides non-invasive, directionally sensitive PD detection in electrical equipment by connecting from the High Voltage (HV) cable shield or isolated phase bus (IPB) enclosure to ground. The GPCS is often used in conjunction with coupling capacitors to provide a comprehensive monitoring solution.

Operation

PD activity in electrical equipment will produce high frequency signals that are transmitted through the primary conductor. This signal induces a current in the shield.

The GPCS sensor is designed to transmit only the high frequency pulses caused by partial discharge. The GPCS sensor acts as a band pass device providing an alternative ground path for the induced high frequency signal in the shield while still maintaining the integrity of the insulation at the power frequency.

The high frequency pulses are detected and transmitted to a monitoring instrument via a coaxial cable connection. To achieve this, a GPCS is installed across the insulated joint between the conductor shield (or IPB) and ground as shown.

Application

High Voltage conductors usually are installed with some type of shield. In generator applications, the duct on the IPB acts as that shield. This shield equalises the electrical stress around the conductor and diverts any leakage current to ground through a ground connection.

The shield is connected to ground at only one point to prevent circulating currents. The other end of the shield (or the other end of the duct around the isolated phase bus) will be insulated from ground.

Directional Sensitivity Helps in Locating PD Sources

The GPCS sensor is current-direction-sensitive. This sensitivity provides a signal polarity change depending on the location of the PD source, speeding your ability to locate equipment problems.

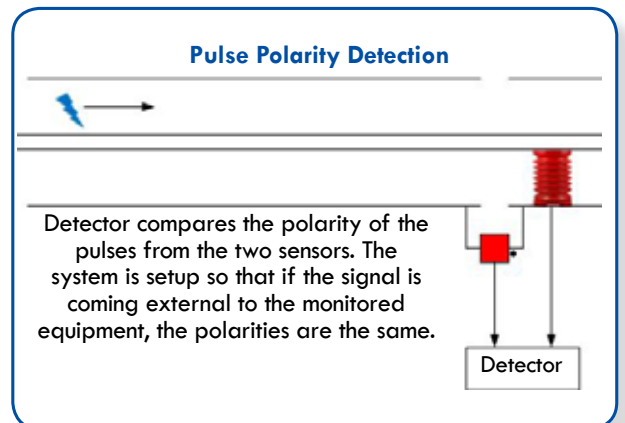

SPECIFICATIONS

Power Requirement:	None (This is a passive device)
Temperature Range:	-40°C to 85°C / -40°F to 185°F
Frequency Range:	500kHz to 75MHz

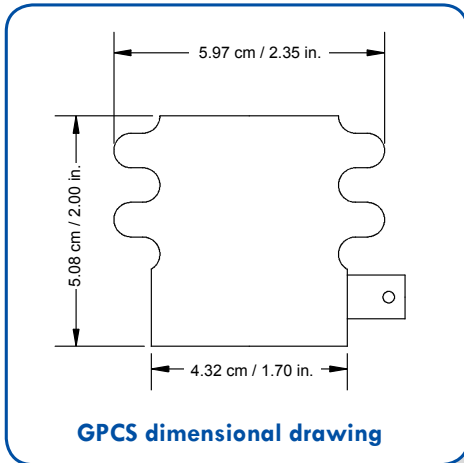

PX-TOOL

GROUND PATH CURRENT SENSOR & ACCESSORIES — ORDERING INFORMATION

Part #	Description
GPCS-K	One (1) Ground Path Current Sensor and Installation Kit including: <ul style="list-style-type: none"> • BNC Connector • Termination/mounting screws • Installation conductors including (0.46 m / 1.5 ft.) of tinned copper braid and a (102 mm / 4 in.) copper/brass strip to facilitate various installation alternatives • Heat-shrink tubing for installation over the BNC Connector
COAX-500	Coax cable, type RG 58A/U, (152 m / 500 ft.) in length
COAX-1000	Coax cable, type RG 58A/U, (305 m / 1000 ft.) in length
PX-TOOL	Tool kit to install BNC connectors including: <ul style="list-style-type: none"> (1) parts compartment box (1) Coaxial Cable Stripper (1) Crimper, Square, 10-28 AWG (1) Multi-diameter step drill bit (25) #22 AWG, 6 mm ferrules (orange) (25) #20 AWG, 12 mm ferrules (white) (25) #16 AWG, 12 mm ferrules (black)

Coaxial Cable is not included. Order desired length of coaxial cable separately.

Applications

- Generators
- Power Transformers
- Switchgear
- Motors
- Iso-Phase Bus



The Radio Frequency Current Transformer (RFCT) provides non-invasive, directionally sensitive PD detection on electrical equipment by detecting activity in the ground connection.

Operation

Radio Frequency Current Transformers (RFCT) measure PD in the ground circuits of a variety of electrical equipment. Typically RFCTs are installed around cable termination shield connections, neutral ground wires and external core ground connections on large power transformers and isolated surge capacitors typically found on large motors.

Construction

The RFCT is made with a special ferrite core and winding which is moulded with a durable epoxy coating.

Expanding the Zone of Coverage

The frequency response of an RFCT is much different than that of a coupling capacitor; therefore it's "Zone of Coverage" is much larger. However, since it is installed in ground circuits, it may be subject to much higher noise levels.

On cable terminations, the grounded termination shield is passed through the RFCT, prior to the connection to ground. This will allow one to "look" down the cable. How far one can "see" down the cable will depend on the condition of the cable shield, type of shield and the type of cable insulation.

Experience has shown that one can "see" further down a cross-linked polyethylene (XPLE) cable than ethylene-propylene rubber (EPR) cable. Statistics indicate that at least 90% of cable failures are at terminations and splices.

Wire Termination Options

The RFCT is available with two wiring options. The sensor can be provided with a 1/2" NPT fitting with a type C, conduit body allowing installation and access to the interior of the conduit system for inspection, pulling and maintenance. This termination option (Option C) is preferred for outdoor applications or other installations where conduit is used to protect the coax sensing cables.



RFCT with Option C

A flying lead option (Option L) has two conductors that can be spliced onto coaxial cable. This termination option is often used for switchgear applications where sensing leads do not need to be installed into conduit.



RFCT with Option L

Both wiring options are available in three inner diameter sizes to accommodate the industry's conductor sizes.

Inner Diameter (I.D.) Conductor Sizes

2.54 (cm) / 1.0 (in.) I.D.
5.59 (cm) / 2.2 (in.) I.D.
10.16 (cm) / 4.0 (in.) I.D.

SPECIFICATIONS

Power Requirement:	None (This is a passive device)
Temperature Range:	-40°C to 85°C / -40°F to 185°F
Frequency Range:	250kHz to 50MHz

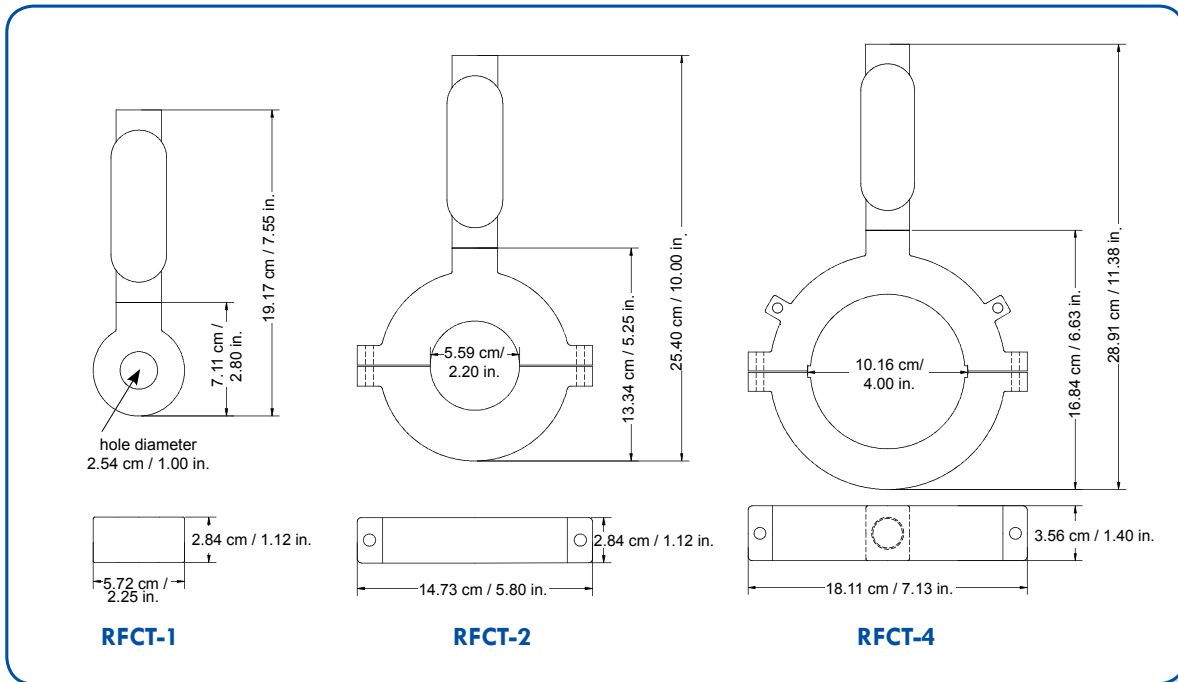

RFCT — ORDERING INFORMATION

Part #	Description	Inner Diameter (I.D.)	Conductor Size	Wire termination method
RFCT-1C	One RFCT	2.54 (cm) / 1.0 (in.) I.D.		Includes a Conduit fitting with ½" NPT type C, conduit body, seal and cover
RFCT-1L	One RFCT	2.54 (cm) / 1.0 (in.) I.D.		Flying leads provided
RFCT-2C	One RFCT	5.59 (cm) / 2.2 (in.) I.D.		Includes a Conduit fitting with ½" NPT type C, conduit body, seal and cover
RFCT-2L	One RFCT	5.59 (cm) / 2.2 (in.) I.D.		Flying leads provided
RFCT-4C	One RFCT	10.16 (cm) / 4.0 (in.) I.D.		Includes a Conduit fitting with ½" NPT type C, conduit body, seal and cover
RFCT-4L	One RFCT	10.16 (cm) / 4.0 (in.) I.D.		Flying leads provided

Applications

- Power Transformers
- Iso-Phase Bus
- HVCTs



The BAU bushing sensors provide a non-invasive, dual purpose sensor which detects problems in the bushing or within the main transformer tank.

Dual Purpose Sensor

Type BAU sensors provide both a power frequency and high frequency signal to Dynamic Ratings monitoring equipment. These monitor the bushing insulation for partial discharges that may be occurring in bushings or windings.

Bushing Sensors are installed in a transformers bushing test/capacitance tap. BAU sensors are designed with three main sections (shown below).

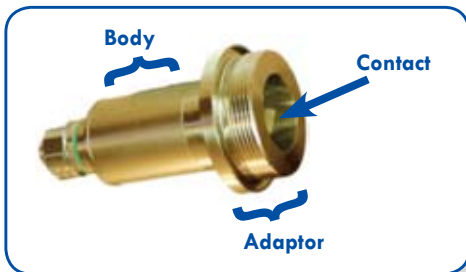

In all cases, the body of the sensor is same. Only the adapter head and contact will change to accommodate the design of the bushing tap.

Custom Adaptors for Various Tap Styles

DR has a continually growing library of different bushing test tap adaptors. Presently, there are 34 different adaptor types to choose from. The application engineering team at Dynamic Ratings will review your bushing drawings and select the proper adaptor for your specific application. New designs can be manufactured in three weeks.

Safety Advantages

Under normal operation, the bushing test/capacitance tap is grounded. When the sensor is installed, the tap is grounded at the monitoring equipment. The protection features built into the main body of the sensor ensure that if the cable becomes disconnected, the capacitive tap will be grounded within the main body of the sensor.

Dynamic Ratings has three levels of protection built into the body of every sensor.

1. **Open Circuit / Voltage Limiter** – There are four voltage limiters used in the sensor. A current balance circuit is used to distribute the stress equally. This protection circuit will limit the output voltage to around 20 volts AC if the wiring or the monitoring systems loses the ground connection. The circuit has a safety factor of two.
2. **Surge Protection** – It is necessary to provide surge protection for switching and system transients. The two surge protection circuits exist for this purpose. The circuit has a safety factor of two.
3. **Fail Safe Circuit** – A Fail Safe Circuit is included that will automatically ground the tap inside the body of the sensor should the open circuit and/or surge protection fail.



Bushing Sensors

Easy Removal for Off-Line Testing

The Main Body of the sensor can be easily detached from the Adaptor by the removal of three screws. Once the main body is disconnected, the test tap of the bushing can be accessed directly or the adaptor can be removed from the bushing to provide additional room when needed.

Remove screws
for off-line
testing



Cable Included

BAU bushing sensors are provided with (25m / 82 ft.) of coaxial cable. The cable length can be shortened (cut), on-site as needed. If longer lengths are required order the length desired from the accessories table below.

Pre-amplifier Option for use with Rogowski Coils

For installations including a Rogowski Coil, a pre-amplifier installs into an LB at the sensor. The pre-amplifier circuit is potted inside the LB to provide protection from moisture and vibration. The flex jacket protecting the wires of the RC coil slides over the barb fitting on the LB. The wires from the RC coil connect to the pre-amplifier.

The pre-amplifier is then connected to the Coaxial cable extending back to the monitor using the supplied splice connectors (Coaxial Cable is ordered separately).



BAU with Pre-amplifier

High Voltage Current Transformer Sensors

The BAU-HVCT is a sensor designed for use on high-voltage current transformers (HVCT) to monitor the power factor and the capacitance of a set of three HVCTs. The BAU-HVCT includes the same three levels of safety advantages as provided in BAU transformer bushing sensors.

The BAU-HVCT is a compact, accurate sensor (shown below) commonly installed in series with the grounding wire in the CT junction box.



HVCT Sensor



Typical CT junction box

Type BAU-HVCT sensors can provide partial-discharge signals to Dynamic Ratings bushing and/or partial-discharge monitors or analysers.

BAU SENSORS & ACCESSORIES — ORDERING INFORMATION

Part #	Description	Ordering Requirements and Content Notes
BAU-xx*	A bushing sensor with (25 m / 82 ft.) of coaxial cable.	Dynamic Ratings will determine the exact part number after reviewing the drawing of the bushing. Customer to provide a copy of the bushing drawing at the time of order.
BAU-xx*-A	A bushing sensor with pre-amplifier for use with a Rogowski Coil and (25 m / 82 ft.) of coaxial cable for the bushing Pf/capacitance sensor.	Dynamic Ratings will determine the exact part number after reviewing the drawing of the bushing. Customer to provide a copy of the bushing drawing at the time of order. Rogowski coil must be ordered separately.
BAU-HVCT	A HVCT sensor with flying leads and a field wiring kit.	Coaxial cable must be ordered separately.

* xx = Dynamic Ratings will determine the exact part number after reviewing the drawing of the bushing. One sensor is supplied per part number. BAU-xx and BAU-xx-A sensors are typically required in sets of 3.

COAX-500	Coax cable, type RG 58A/U, (152 m / 500 ft.) in length
COAX-1000	Coax cable, type RG 58A/U, (305 m / 1000 ft.) in length

Coaxial Cable is not included. Order desired length of coaxial cable separately.

Industries Served

- Power Transformers



A Dynamic Ratings Rogowski Coil (RC) is a polarity sensitive air-core high frequency current transformer.

Operation

Typically RCs are used on high voltage power transformer applications. Partial discharge activity and many noise signatures are found in the high frequency range.

RCs are installed around the base (shown above) of high voltage bushings rated 132kV or higher. The length of an RC is based on the diameter of the bushing at the point of installation.

RC's are used in conjunction with Dynamic Ratings bushing type-BAU sensors. Pulse polarity from both sensors is compared to determine signal direction.

Design Advantages

Rogowski Coils are non-intrusive, avoiding the complexity and risks associated with inserting sensors into the transformer tank.

Features & Benefits

RCs use materials proven to resist UV deterioration and survive the harsh environments where they are installed.

A factory installed pre-amplifier directly connected to the BAU sensor when RCs are used. By comparing the simultaneous polarity of the two signals it is easily determined if the signals are external or internal to the transformer.

Easy Installation

Multiple design factors make the DR manufactured Rogowski Coil very easy to install.

- The RC is available in multiple sizes to fit a wide variety of bushing designs.
- A buckle strap is provided to allow quick and easy installation.
- The BAU bushing sensors can be ordered with the pre-amp built into the termination box. The RC terminates into the termination box and the coaxial conductor will be routed through the same conduit as the BAU bushing sensor.

Directionally Sensitive

The RC provides a directionally sensitive signal allowing monitoring systems to identify the direction the PD activity is coming from. Directionally sensitive filters allow the monitor to filter out PD signals that are being transmitted from outside the monitored transformer.

With this added level of filtering, the monitor can utilize lower frequencies in the detection which provides deeper “visibility” of PD within the windings without the concern associated with external PD sources.



Rogowski Coil

Selecting the Proper RC Size

Rogowski coils are fitted to the base of the bushing below the bottom skirt. RC sensors are selected by length, to encircle the circumference of a bushing’s porcelain base.

The total length of the sensor needs to consider the buckle length of 6 inches. Hence, an RC-2.0 should be selected for an application where the circumference is (0.762 m / 2.5 ft.).

ROGOWSKI COIL SENSORS† & ACCESSORIES — ORDERING INFORMATION

Part#	Description
RC-1.6 *	A Rogowski Coil of 0.488 m / (1.6 ft.) in length (Circumference)
RC-2.0 *	A Rogowski Coil of 0.610 m / (2.0 ft.) in length (Circumference)
RC-2.5 *	A Rogowski Coil of 0.762 m / (2.5 ft.) in length (Circumference)
RC-3.0 *	A Rogowski Coil of 0.914 m / (3.0 ft.) in length (Circumference)
RC-3.5 *	A Rogowski Coil of 1.070 m / (3.5 ft.) in length (Circumference)
RC-4.0 *	A Rogowski Coil of 1.220 m / (4.0 ft.) in length (Circumference)
RC-4.5 *	A Rogowski Coil of 1.370 m / (4.5 ft.) in length (Circumference)
RC-5.0 *	A Rogowski Coil of 1.520 m / (5.0 ft.) in length (Circumference)
RC-5.5 *	A Rogowski Coil of 1.680 m / (5.5 ft.) in length (Circumference)
RC-6.0 *	A Rogowski Coil of 1.830 m / (6.0 ft.) in length (Circumference)
RC-6.5 *	A Rogowski Coil of 1.980 m / (6.5 ft.) in length (Circumference)

† Use on bushings rated 132kV or higher only.

COAX-500 *	Coax cable, type RG 58A/U, (152 m / 500 ft.) in length
COAX-1000 *	Coax cable, type RG 58A/U, (305 m / 1000 ft.) in length

- * • One sensor is supplied per part number.
- The sensor must be used with a BAU-xx-A bushing sensor with a pre-amplifier.
- Coax cable is needed to connect from the pre-amplifier to the monitoring instrument. Coax cable must be ordered separately.
- Customer to provide a drawing of the transformer bushing to be monitored to ensure the appropriate sensor design.

Critical Measurements

- Ambient Temperature
- Ambient Humidity
- Load Current
- Top Oil Temperature

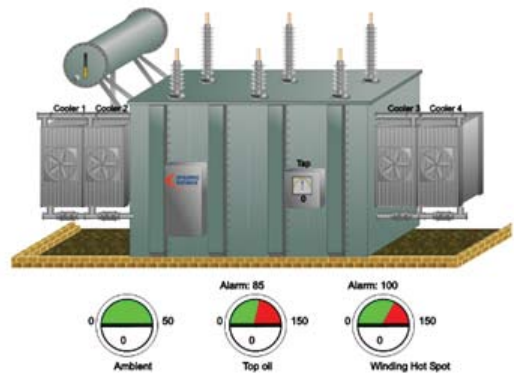

Partial discharge activity and bushing health can be affected significantly by environmental conditions including temperature and humidity.

In equipment, PD activity is known to increase as humidity decreases (voids in the insulation tend to expand when the insulation gets drier). In transformers, the bushing condition often gets worse as its temperature increases.

Ambient Temperature and Humidity

For DR monitoring systems with an enclosure, the temperature and humidity sensors are installed in a weather tight fitting protruding from the bottom of the enclosure.

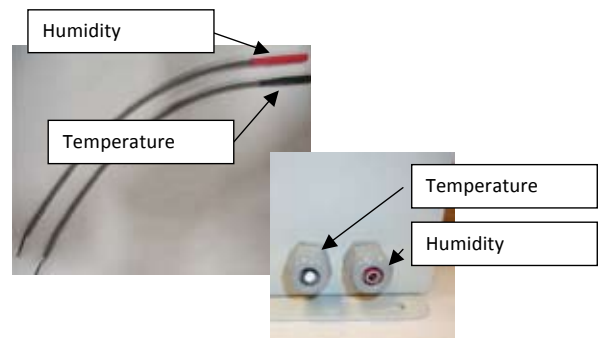

Design Advantages

PD systems that monitor environmental and equipment operating conditions can provide additional benefits and data correlation. The ability to correlate changes in PD activity based on changes in load, temperature or humidity can enable a Subject Matter Expert to identify the inception point where the problem starts. If these conditions can be controlled or at least predicted, it is possible to better manage the risk and improve equipment reliability and personnel safety.

The ambient temperature and humidity sensors can also be included inside an enclosure or wired onto a sub-panel.

AMBIENT SENSORS — ORDERING INFORMATION

Part #	Description
AmbT	An ambient temperature sensor, total length with wire leads of (0.3m / 1 ft.)
AmbH	An ambient humidity sensor, total length with wire leads of (0.3m / 1 ft.)

Top Oil Temperature Sensor – Magnetic Mount

The Dynamic Ratings Magnetic Mount temperature sensors provide an easy method for measuring transformer top oil, bottom oil or load tap changer tank temperatures.

- The sensor is available with a 1/2" NPT fitting for use with conduit or with stainless steel flexible armored cable.
- The sensors are available in either a 3 wire PT-100 RTD output or 4-20mA output.
- The sensors nominal dimensions are: bottom diameter of (7.0 cm / 2.75 in.) and (3.8 cm / 1.5 in.) in height.



MMTS Sensors

MAGNETIC MOUNT TEMPERATURE SENSOR — ORDERING INFORMATION

Part #	Description	Sensor Output	Wire termination method
MMTS-3C	One magnetic mount sensor	3 Wire PT-100 RTD	Includes a 1/2" NPT conduit connection
MMTS-3W	One magnetic mount sensor	3 Wire PT-100 RTD	Includes a (7.6m / 25 ft.) of Stainless Steel armored cable with flying leads connection
MMTS-4C	One magnetic mount sensor	4 - 20mA output	Includes a 1/2" NPT conduit connection
MMTS-4W	One magnetic mount sensor	4 - 20mA output	Includes a (7.6m / 25 ft.) of Stainless Steel armored cable with flying leads connection

Top Oil Temperature Sensor – Thermal Well Design

For new transformer applications and installations where a spare thermal well is available, Dynamic Ratings offers a spring loaded, 3 Wire, PT-100 RTD sensor part number SE-060. The sensor can be cut to accommodate almost any thermal well depth. The 1/4" diameter shaft ensures the sensor can be installed into most common thermal wells. The spring loaded feature ensures a solid contact of the sensor tip to the bottom of the thermal well.

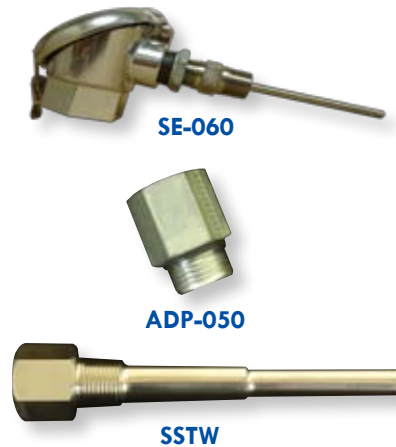

THERMAL WELL SENSORS & ACCESSORIES — ORDERING INFORMATION

Part #	Description
SE-060	A 3 wire, PT-100, RTD, temperature probe with NEMA 4 connection head. 1/2" 14 NPT conduit connection
ADP-050	An adaptor to fit the sensor into a 1/2" female tapered thread x 1/2" male straight thread with an O-ring seal
SSTW	A 316 stainless steel thermal well

Load Current Sensors

The DM Series product utilises a split core CT with a burden resistor for sensing of load current. The primary of the CT allows for monitoring of loads up to 75 Amp. The split core design allows for installation onto existing circuits with conductor sizes up to (10 mm / 0.4 in) in spaces less than 1.5 sq. inches. The sensor is supplied with the burden resistor installed and (19 m / 62 ft.) of cable.

Often customers who desire to implement PD monitoring systems on motor applications find they do not have any CT for load current sensing. For applications where no CT is available the following flexible CT's are available: CTF-400 with a capability of (0 - 400A) or CTF-600 (0-600A). All CTF sensors include an AuxCT with its burden resistor for direct connection to a DM series monitor.



AuxCT



CTF Sensor Install



CTF Sensors

LOAD CURRENT SENSOR — ORDERING INFORMATION

<i>Part #</i>	<i>Sensing range</i>	<i>Description</i>
AuxCT	0-75 Amps	A current transformer with burden resistor and (19 m / 62 ft.) of 22 AWG cable
CTF-400	0-400 Amps	A load current sensor and (19 m / 62 ft.) of 22 AWG cable with a mV output for connection to a DM series monitor
CTF-600	0-600 Amps	A load current sensor and (19 m / 62 ft.) of 22 AWG cable with a mV output for connection to a DM series monitor



Asia /Africa /United Kingdom

+61 3 9574 7722

sales.asia@dynamicratings.com

Americas /Europe /India /Middle East

+1 262 746-1230

sales.us@dynamicratings.com

www.dynamicratings.com